

RELATIONSHIP BETWEEN COUPLING AND THE CONTROLLABILITY GRAMMIAN IN CO-DESIGN PROBLEMS

D. L. Peters*, P. Y. Papalambros* and A. G. Ulsoy*

Abstract—Optimization of smart products requires optimizing the design of both the artifact and its controller. The existence of coupling between these problems currently cannot be established until they are solved. If coupling is expected to be present, then the problem is often solved as a simultaneous optimization. In this paper, it is shown that in several classical control problem formulations the presence of coupling can be established *a priori* by evaluating derivatives of the controllability Grammian. The concepts developed are demonstrated on a simple positioning gantry example.

I. INTRODUCTION

The development of ‘smart’ products will solve a wide range of problems in diverse fields. Some applications are structures with active control [1], [2], [3], mechatronics [4], [5], mechanisms [6], [7], and microelectrical mechanical systems (MEMS) [8], [9], [10]. Smart products consist of both a physical system, or artifact, and a controller. To effectively design these products, the possible existence of coupling, or interdependence in the design of the artifact and of the controller, must be considered. Knowledge about coupling provides insight into the nature of the tradeoffs present and guides the choice of an appropriate solution method.

In the optimal design and control, i.e., co-design of these systems, there are generally two objective functions. One objective function f_a applies to the artifact, and the other objective f_c applies to the controller. The full set of variables consists of artifact design variables \mathbf{d}_a and controller design variables \mathbf{d}_c . Typically, there are also inequality and equality constraints associated with both the artifact and controller design problems, i.e., \mathbf{g}_a , \mathbf{h}_a and \mathbf{g}_c , \mathbf{h}_c , respectively. In the case of bi-directional coupling, both objective functions and sets of constraints depend on both sets of variables. In uni-directional coupling, the artifact objective function and constraints are functions only of the artifact variables, while the controller objective function and constraints depend on both artifact and controller variables. In this work, only uni-directional coupling will be addressed.

The optimization problem for the system, i.e., co-design, is often formulated as a combination of the individual objectives. Often, this objective is a linear combination, with weights applied to the individual objectives, as follows.

$$\min_{\mathbf{d}_a, \mathbf{d}_c} w_a f_a(\mathbf{d}_a) + w_c f_c(\mathbf{d}_a, \mathbf{d}_c) \quad (1)$$

subject to

$$\mathbf{g}_a(\mathbf{d}_a) \leq \mathbf{0} \quad (2)$$

$$\mathbf{h}_a(\mathbf{d}_a) = \mathbf{0} \quad (3)$$

$$\mathbf{g}_c(\mathbf{d}_a, \mathbf{d}_c) \leq \mathbf{0} \quad (4)$$

$$\mathbf{h}_c(\mathbf{d}_a, \mathbf{d}_c) = \mathbf{0} \quad (5)$$

Two issues involved in the optimal co-design of coupled systems are identification of tradeoffs between the two objectives and selection of appropriate methods of solution. Although the solutions found in a simultaneous, or all-in-one, optimization are system-optimal, this approach is computationally intensive and precludes the use of many specialized techniques developed for optimization in specific disciplines. A sequential approach, while easier to solve, does not typically find the system optimum. It would be useful to identify and quantify coupling prior to choosing a solution method; however, existing methods used to determine coupling require knowledge of the system solution, and thus cannot be calculated until the problem has been solved. In this paper it is shown that for some problem formulations, representing important classical control problems, coupling can be determined *a priori* using the controllability Grammian, which offers a significant advantage in choosing appropriate methods of solution.

II. METRICS USED FOR COUPLING AND CONTROLLABILITY

Several metrics have been developed for quantification of coupling. These metrics include a vector based on optimality conditions [11], [12], a matrix based on the Global Sensitivity Equations (GSEs) [13], and the sensitivities that appear in the GSEs [14]. The metric used here is the vector description of coupling given in Eq. (6), which is applicable to a co-design problem with uni-directional coupling [11]. This metric is preferred for such problems for its relatively simple form and suitability to this particular problem [15].

$$\Gamma_v = \frac{w_c}{w_a} \left(\frac{\partial f_c}{\partial \mathbf{d}_a} + \frac{\partial f_c}{\partial \mathbf{d}_c} \frac{d\mathbf{d}_c}{d\mathbf{d}_a} \right) \quad (6)$$

where Γ_v must be evaluated at the optimal solution to Eqs.(1)-(5). Consequently, the coupling cannot be determined *a priori*, i.e., before the simultaneous co-design problem in Eqs. (1)-(5) is solved. When $\Gamma_v = \mathbf{0}$, the artifact design problem

$$\min_{\mathbf{d}_a} f_a(\mathbf{d}_a) \quad (7)$$

subject to

*Department of Mechanical Engineering, University of Michigan, Ann Arbor, MI 48108, USA
 dlpeters@umich.edu, pyp@umich.edu, ulsoy@umich.edu

$$\mathbf{g}_a(\mathbf{d}_a) \leq \mathbf{0} \quad (8)$$

$$\mathbf{h}_a(\mathbf{d}_a) = \mathbf{0} \quad (9)$$

can first be solved; then, given the optimal artifact design \mathbf{d}_a^* , the controller design problem

$$\min_{\mathbf{d}_c} f_c(\mathbf{d}_c) \quad (10)$$

subject to

$$\mathbf{g}_c(\mathbf{d}_c) \leq \mathbf{0} \quad (11)$$

$$\mathbf{h}_c(\mathbf{d}_c) = \mathbf{0} \quad (12)$$

can be solved to obtain the same result as obtained from solving the simultaneous co-design problem in Eqs. (1)-(5).

There are several measures of controllability. One metric which is particularly useful in this problem is the controllability Grammian matrix. For a system expressed in the form

$$\dot{\mathbf{x}} = \mathbf{A}\mathbf{x} + \mathbf{B}u \quad (13)$$

$$y = \mathbf{C}\mathbf{x} \quad (14)$$

the controllability Grammian is the matrix

$$\mathbf{W}_c = \int_0^{t_f} \Phi(\tau) \mathbf{B} \mathbf{B}^T \Phi^T(\tau) d\tau \quad (15)$$

where $\Phi(\tau)$ is the state transition matrix [16]. If the matrices \mathbf{A} and \mathbf{B} are time-invariant, then \mathbf{W}_c is given by

$$\mathbf{W}_c = \int_0^{t_f} e^{\mathbf{A}\tau} \mathbf{B} \mathbf{B}^T e^{\mathbf{A}^T \tau} d\tau \quad (16)$$

In the case where the final time $t_f \rightarrow \infty$, the controllability Grammian can also be found by solving the Lyapunov equation

$$\mathbf{A} \mathbf{W}_c^\infty + \mathbf{W}_c^\infty \mathbf{A}^T = -\mathbf{B} \mathbf{B}^T. \quad (17)$$

The controllability Grammian is often used to determine simply whether or not a system is controllable; if it is singular, the system is not controllable. It can also be used to determine the minimum control effort required to move a system from the origin to a final state \mathbf{x}_f at some final time t_f , where the control effort, E , is given by

$$E = \int_0^{t_f} u(t)^2 dt, \quad (18)$$

and its minimum value, E^* , is given by [16]:

$$E^* = \mathbf{x}_f^T \mathbf{W}_c^{-1} \mathbf{x}_f. \quad (19)$$

It is important to note that Eq. (19) is independent of the control architecture; it depends only on the dynamics of the uncontrolled system, i.e., \mathbf{A} and \mathbf{B} , and the final time t_f . The optimal controller performance depends on the controllability Grammian, which is independent of the control architecture and variables, and thus we will show that the Grammian can be used to determine coupling *a priori*.

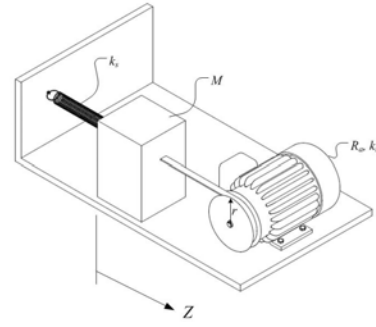

Fig. 1. CONFIGURATION OF POSITIONING GANTRY SYSTEM

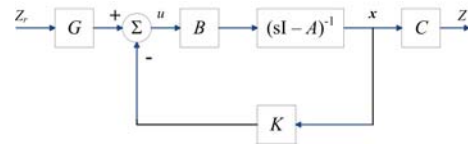

Fig. 2. SCHEMATIC OF SYSTEM CONTROLLER

III. CONFIGURATION OF POSITIONING GANTRY EXAMPLE SYSTEM

Consider the system shown in Fig. 1, representing a simple model of a positioning gantry. In this system, a mass M is connected to a fixed surface by a linear spring with constant k_s . A flexible belt connects to the mass and wraps around a pulley with radius r , which is mounted on a DC motor with armature resistance R_a and motor constant k_t . The displacement of the mass from its original position is Z . The system can be modeled by the following equations:

$$\dot{\mathbf{x}} = \mathbf{A}\mathbf{x} + \mathbf{B}u \quad (20)$$

$$Z = \mathbf{C}\mathbf{x} \quad (21)$$

$$\mathbf{x} = \begin{bmatrix} Z \\ \dot{Z} \end{bmatrix} \quad (22)$$

$$\mathbf{A} = \begin{bmatrix} 0 & 1 \\ -\frac{k}{m} & -\frac{b}{m} \end{bmatrix} \quad (23)$$

$$\mathbf{B} = \begin{bmatrix} 0 \\ \frac{1}{m} \end{bmatrix} \quad (24)$$

$$\mathbf{C} = [1 \ 0] \quad (25)$$

where $m = \frac{MrR_a}{k_t}$, $b = \frac{k_t}{r}$, and $k = \frac{k_s r R_a}{k_t}$. A state-feedback controller with gains $\mathbf{K} = [K_1 \ K_2]$ and precompensator G is applied to the system, as shown in Fig. 2, to generate the input voltage u to the motor. The steady-state voltage is denoted as u_{ss} . Values of parameters are $R_a = 2 \text{ k}\Omega$, $M = 2 \text{ kg}$, $k_s = 2/\text{textN/mm}$, and $u_{ss} = 10 \text{ V}$. The design variables r and k_t are found in the optimization of the gantry system. All optimizations are performed with Matlab's *fmincon* function.

IV. RELATIONSHIPS BETWEEN Γ_v AND \mathbf{W}_c

Consider three types of objectives representing classical control problems. In the first case, the case of fixed terminal time [17], energy is of primary interest, and the problem is formulated to minimize control effort. In the second case, the speed of response is of importance; a constraint is placed on control effort, but the problem objective is to minimize the response time. This is representative of unspecified terminal time problems [17]. In the third case, the control problem is formulated as a classical Linear Quadratic Regulator (LQR) problem, in which a combination of control effort and the system states is minimized.

All of these cases have the following characteristics:

- 1) The system can be modeled in state-space form as linear and time-invariant.
- 2) The matrices \mathbf{A} and \mathbf{B} may be functions of the artifact design variables \mathbf{d}_a .
- 3) The system exhibits uni-directional coupling, as in (1) - (5). The objective function for the optimization is a weighted sum of the two individual objectives, where the weights w_a and w_c are strictly positive.

A. Case I: Control Effort as Objective

In Case I, the controller objective function is the control effort required to move the system from the origin to a state \mathbf{x}_f at some specified time t_f , where t_f is a parameter, as given by Eq. (18). Using (19) and (18), the controller objective function f_c will satisfy the relation

$$f_c \geq \mathbf{x}_f^T \mathbf{W}_c^{-1} \mathbf{x}_f \quad (26)$$

where the equality applies if an optimal controller is chosen. The coupling vector is computed from (6) as follows:

$$\Gamma_v = \frac{w_c}{w_a} \frac{\partial}{\partial \mathbf{d}_a} (\mathbf{x}_f^T \mathbf{W}_c^{-1} \mathbf{x}_f) \quad (27)$$

$$\Gamma_v = \frac{w_c}{w_a} \begin{bmatrix} \mathbf{x}_f^T \frac{\partial \mathbf{W}_c^{-1}}{\partial d_{a_1}} \mathbf{x}_f + 2\mathbf{x}_f^T \mathbf{W}_c^{-1} \frac{\partial \mathbf{x}_f}{\partial d_{a_1}} \\ \mathbf{x}_f^T \frac{\partial \mathbf{W}_c^{-1}}{\partial d_{a_2}} \mathbf{x}_f + 2\mathbf{x}_f^T \mathbf{W}_c^{-1} \frac{\partial \mathbf{x}_f}{\partial d_{a_2}} \\ \vdots \\ \mathbf{x}_f^T \frac{\partial \mathbf{W}_c^{-1}}{\partial d_{a_n}} \mathbf{x}_f + 2\mathbf{x}_f^T \mathbf{W}_c^{-1} \frac{\partial \mathbf{x}_f}{\partial d_{a_n}} \end{bmatrix}^T \quad (28)$$

Given a particular system, it is possible to express the coupling in terms of the artifact design variables \mathbf{d}_a , constants, and parameters in the problem. If the i th term in the coupling vector vanishes, then the i th artifact design variable will not participate in the coupling. If all terms in the coupling vector vanish, then the problem is uncoupled. A particular coupling term will vanish under one of two conditions:

- 1) The vectors \mathbf{x}_f and $\left(2\mathbf{W}_c^{-1} \frac{\partial \mathbf{x}_f}{\partial d_{a_i}} + \frac{\partial \mathbf{W}_c^{-1}}{\partial d_{a_i}} \mathbf{x}_f\right)$ are orthogonal.
- 2) $\frac{\partial \mathbf{x}_f}{\partial d_{a_i}} = -\frac{1}{2} \mathbf{W}_c \frac{\partial \mathbf{W}_c^{-1}}{\partial d_{a_i}} \mathbf{x}_f$.

This can occur when the variables \mathbf{d}_a result in changes in the control effort that counteract the effects of the changes in \mathbf{x}_f . As an example, an increased \mathbf{x}_f could be associated with a problem configuration with a more efficient use of control effort. Within the class of problems denoted here as Case I, there are two sub-classes that are of interest.

Case Ia: Final State as a Parameter: If the final state \mathbf{x}_f is a specified parameter, then the expression given in (28) can be simplified to

$$\Gamma_v = \frac{w_c}{w_a} \begin{bmatrix} \mathbf{x}_f^T \frac{\partial \mathbf{W}_c^{-1}}{\partial d_{a_1}} \mathbf{x}_f \\ \mathbf{x}_f^T \frac{\partial \mathbf{W}_c^{-1}}{\partial d_{a_2}} \mathbf{x}_f \\ \vdots \\ \mathbf{x}_f^T \frac{\partial \mathbf{W}_c^{-1}}{\partial d_{a_n}} \mathbf{x}_f \end{bmatrix}^T \quad (29)$$

If \mathbf{W}_c is not a function of \mathbf{d}_a , then $\frac{\partial \mathbf{W}_c^{-1}}{\partial d_a} = \mathbf{0}$ for any value of \mathbf{d}_a . In this case, each component in this relation will vanish. Therefore, $\Gamma_v = \mathbf{0}$, and the system is uncoupled. Note that while this will guarantee decoupling, it is still possible for the system to decouple if $\frac{\partial \mathbf{W}_c^{-1}}{\partial d_a} \neq \mathbf{0}$. Specific values of \mathbf{x}_f may cause particular terms to drop out of the final result, or the vector $\frac{\partial \mathbf{W}_c^{-1}}{\partial d_a} \mathbf{x}_f$ may be orthogonal to \mathbf{x}_f .

Case Ib: Constant Controllability Grammian: Assume that the controllability Grammian \mathbf{W}_c is not dependent on \mathbf{d}_a . This may occur when the variables \mathbf{d}_a represent conversions from one form of energy to another, which will not change the total effort required to control the system. Then, the coupling vector Γ_v can be expressed as

$$\Gamma_v = \frac{w_c}{w_a} \begin{bmatrix} 2\mathbf{x}_f^T \mathbf{W}_c^{-1} \frac{\partial \mathbf{x}_f}{\partial d_{a_1}} \\ 2\mathbf{x}_f^T \mathbf{W}_c^{-1} \frac{\partial \mathbf{x}_f}{\partial d_{a_2}} \\ \vdots \\ 2\mathbf{x}_f^T \mathbf{W}_c^{-1} \frac{\partial \mathbf{x}_f}{\partial d_{a_n}} \end{bmatrix}^T \quad (30)$$

In this case, a term in the coupling vector will vanish if $\frac{\partial \mathbf{x}_f}{\partial d_{a_i}} = \mathbf{0}$ or if the vectors $\frac{\partial \mathbf{x}_f}{\partial d_{a_i}}$ and $\mathbf{W}_c^{-1} \mathbf{x}_f$ are orthogonal.

Positioning Gantry Example: For the positioning gantry described in Section II, the following objectives and constraints are selected:

$$f_a(k_t, r) = -Z_f \quad (31)$$

$$2.5 \leq r \leq 7.5 \quad (32)$$

$$5 \leq k_t \leq 20 \quad (33)$$

where the final displacement Z_f represents the peak displacement, with a 10% overshoot over the steady-state displacement, Z_{ss} .

$$Z_f = 1.1Z_{ss} = \frac{1.1u_{ss}k_t}{rR_a k_s} \quad (34)$$

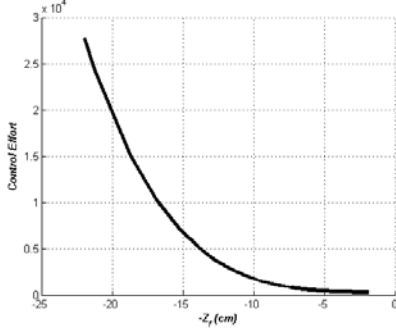

Fig. 3. PARETO FRONTIER FOR POSITIONING GANTRY EXAMPLE OF CASE I

The controller objective is

$$f_c(k_t, r, K_1, K_2, G) = \int_0^{t_f} (u(t))^2 dt \quad (35)$$

and this optimization problem clearly fits the description for a Case I problem. The controllability Grammian $\mathbf{W}_c(t_f)$ of this system is given by

$$\mathbf{W}_c(t_f) = \begin{bmatrix} W_c(1,1) & W_c(1,2) \\ W_c(2,1) & W_c(2,2) \end{bmatrix} \quad (36)$$

where the individual terms are as follows:

$$W_c(1,1) = \frac{1}{2bk} - \frac{2me^{-\frac{b}{m}t_f}}{b(4mk - b^2)} + \frac{e^{-\frac{b}{m}t_f}}{2k\sqrt{4mk - b^2}} \sin\left(\sqrt{4mk - b^2}\frac{t_f}{m}\right) + \frac{e^{-\frac{b}{m}t_f}}{2k(4mk - b^2)} \cos\left(\sqrt{4mk - b^2}\frac{t_f}{m}\right) \quad (37)$$

$$W_c(1,2) = \frac{e^{-\frac{b}{m}t_f}}{4mk - b^2} \left(1 - \cos\left(\sqrt{4mk - b^2}\frac{t_f}{m}\right)\right) \quad (38)$$

$$W_c(2,1) = \frac{e^{-\frac{b}{m}t_f}}{4mk - b^2} \left(1 - \cos\left(\sqrt{4mk - b^2}\frac{t_f}{m}\right)\right) \quad (39)$$

$$W_c(2,2) = \frac{1}{2bm} - \frac{4ke^{-\frac{b}{m}t_f}}{b(4mk - b^2)} + \frac{e^{-\frac{b}{m}t_f}}{m(4mk - b^2)^{3/2}} \sin\left(\frac{t_f}{m}\sqrt{4mk - b^2}\right) - \frac{be^{-\frac{b}{m}t_f}}{m(4mk - b^2)} \cos\left(\frac{t_f}{m}\sqrt{4mk - b^2}\right) \quad (40)$$

Taking derivatives of both \mathbf{x}_f and $\mathbf{W}_c(t_f)$, it can be shown that there are no feasible values of r and k_t for which $\mathbf{\Gamma}_v = \mathbf{0}$. Therefore, it is concluded that the problem will be coupled, and an appropriate solution method for a coupled problem should be chosen. When the simultaneous co-design problem is solved, it is seen to be coupled, with the expected tradeoff between the objectives shown in Fig.(3).

B. Case II: Time as Objective

In Case II problems, the controller objective function and constraint are as follows:

$$f_c(\mathbf{d}_a, \mathbf{d}_c) = t_f \quad (41)$$

$$\mathbf{g}_c(\mathbf{d}_a, \mathbf{d}_c) = \int_0^{t_f} u(t)^2 dt - E_{max} \leq 0 \quad (42)$$

Assuming that the constraint is active and that an optimal controller is chosen,

$$\mathbf{x}_f^T \mathbf{W}_c^{-1} \mathbf{x}_f = E_{max}. \quad (43)$$

Taking derivatives of (43) and solving for $\frac{\partial t_f}{\partial d_{a_i}}$,

$$\frac{\partial t_f}{\partial d_{a_i}} = - \frac{2\mathbf{x}_f^T \mathbf{W}_c^{-1} \frac{\partial \mathbf{x}_f}{\partial d_{a_i}} + \mathbf{x}_f^T \frac{\partial \mathbf{W}_c^{-1}}{\partial d_{a_i}} \mathbf{x}_f}{2\mathbf{x}_f^T \mathbf{W}_c^{-1} \frac{\partial \mathbf{x}_f}{\partial t_f} + \mathbf{x}_f^T \frac{\partial \mathbf{W}_c^{-1}}{\partial t_f} \mathbf{x}_f} \quad (44)$$

and the coupling can be expressed as

$$\mathbf{\Gamma}_v = - \frac{w_c}{w_a} \begin{bmatrix} 2\mathbf{x}_f^T \mathbf{W}_c^{-1} \frac{\partial \mathbf{x}_f}{\partial d_{a_1}} + \mathbf{x}_f^T \frac{\partial \mathbf{W}_c^{-1}}{\partial d_{a_1}} \mathbf{x}_f \\ 2\mathbf{x}_f^T \mathbf{W}_c^{-1} \frac{\partial \mathbf{x}_f}{\partial d_{a_2}} + \mathbf{x}_f^T \frac{\partial \mathbf{W}_c^{-1}}{\partial d_{a_2}} \mathbf{x}_f \\ \vdots \\ 2\mathbf{x}_f^T \mathbf{W}_c^{-1} \frac{\partial \mathbf{x}_f}{\partial d_{a_n}} + \mathbf{x}_f^T \frac{\partial \mathbf{W}_c^{-1}}{\partial d_{a_n}} \mathbf{x}_f \end{bmatrix}^T / \left(2\mathbf{x}_f^T \mathbf{W}_c^{-1} \frac{\partial \mathbf{x}_f}{\partial t_f} + \mathbf{x}_f^T \frac{\partial \mathbf{W}_c^{-1}}{\partial t_f} \mathbf{x}_f \right) \quad (45)$$

Note that the coupling vector is parallel to that seen for Case I, and the conditions for decoupling in this problem are mathematically identical. This indicates that the physical conditions under which the problems decouple are also the same. As in Case I, therefore, one situation which would result in decoupling is that in which changes in \mathbf{d}_a produce both a greater displacement \mathbf{x}_f of the system and a more efficient use of the available control effort. Within this class of problems, there are two sub-classes of interest, similar to those discussed for Case I.

Case IIa: Final State as a Parameter: If the final state \mathbf{x}_f is a parameter, then the coupling simplifies to

$$\mathbf{\Gamma}_v = - \frac{w_c}{w_a} \left(\mathbf{x}_f^T \frac{\partial \mathbf{W}_c^{-1}}{\partial t_f} \mathbf{x}_f \right) \begin{bmatrix} \mathbf{x}_f^T \frac{\partial \mathbf{W}_c^{-1}}{\partial d_{a_1}} \mathbf{x}_f \\ \mathbf{x}_f^T \frac{\partial \mathbf{W}_c^{-1}}{\partial d_{a_2}} \mathbf{x}_f \\ \vdots \\ \mathbf{x}_f^T \frac{\partial \mathbf{W}_c^{-1}}{\partial d_{a_n}} \mathbf{x}_f \end{bmatrix}^T \quad (46)$$

and the coupling vector is parallel to that seen in Case Ia, with identical conditions for decoupling.

Constant Controllability Grammian: Assume that the controllability Grammian \mathbf{W}_c is not dependent on \mathbf{d}_a . As in

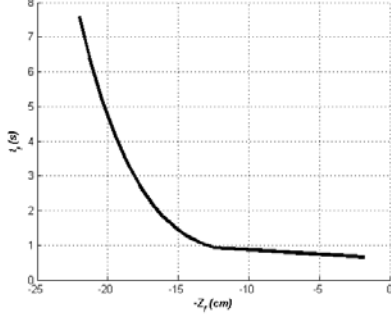

Fig. 4. PARETO FRONTIER FOR POSITIONING GANTRY EXAMPLE OF CASE II

Case I, this can happen when \mathbf{d}_a represents the conversion of energy with no loss. Then, the coupling vector Γ_v can be expressed as

$$\Gamma_v = -\frac{w_c}{w_a \left(\mathbf{x}_f^T \mathbf{W}_c^{-1} \frac{\partial \mathbf{x}_f}{\partial t_f} \right)} \begin{bmatrix} \mathbf{x}_f^T \mathbf{W}_c^{-1} \frac{\partial \mathbf{x}_f}{\partial d_{a_1}} \\ \mathbf{x}_f^T \mathbf{W}_c^{-1} \frac{\partial \mathbf{x}_f}{\partial d_{a_2}} \\ \vdots \\ \mathbf{x}_f^T \mathbf{W}_c^{-1} \frac{\partial \mathbf{x}_f}{\partial d_{a_n}} \end{bmatrix}^T \quad (47)$$

and, in this case, the coupling vector is parallel to that seen in Case Ib, with identical conditions for decoupling.

Positioning Gantry Example: Assume, in this case, that the artifact objective and constraints are as given in Eqs. (31) - (33). The control objective and constraints are as follows:

$$f_c(k_t, r, K_1, K_2, G) = t_f \quad (48)$$

$$g_1(k_t, r, K_1, K_2, G) = \int_0^{t_f} (u(t))^2 dt - E^* \leq 0 \quad (49)$$

Monotonicity analysis indicates that the constraint g_1 will be active; thus, this problem meets the conditions set down for Case II. The controllability Grammian is given by Eqs. (36)-(40). In this case, the coupling is again non-zero for every allowed value of r and k_t . When the problem is solved, the anticipated tradeoff between f_a and f_c is evident, as shown in Fig. 4.

C. Case III: Linear Quadratic Regulator (LQR)

The infinite-time LQR problem is designed to find the optimal control signal $\mathbf{u}(t)$ to transition a system from an initial state $\mathbf{x}_0 = \mathbf{x}(0)$ to the zero state. The optimal control signal is defined as the one which minimizes the cost function

$$J = \int_0^\infty \left(\mathbf{x}(t)^T \mathbf{Q} \mathbf{x}(t) + \mathbf{u}(t)^T \mathbf{R} \mathbf{u}(t) \right) dt. \quad (50)$$

It is well-established [16] that the optimal solution is

$$\mathbf{u}(t) = -\mathbf{K} \mathbf{x}(t) \quad (51)$$

$$\mathbf{K} = \mathbf{R}^{-1} \mathbf{B}^T \mathbf{X} \quad (52)$$

with the precompensator G vanishing because the reference state is the zero state. The matrix \mathbf{X} is the positive semi-definite solution of the algebraic Riccati equation

$$\mathbf{A}^T \mathbf{X} + \mathbf{X} \mathbf{A} - \mathbf{X} \mathbf{B} \mathbf{R}^{-1} \mathbf{B}^T \mathbf{X} + \mathbf{Q} = 0 \quad (53)$$

and the optimal value of J is given by the equation

$$J^* = \mathbf{x}_0^T \mathbf{X} \mathbf{x}_0. \quad (54)$$

If the system is controllable, then it has also been proven [18] that there exists a reduced equivalent transformation of the system, in which

$$J^* = \mathbf{x}_0^T \mathbf{X}_r \mathbf{x}_0 \quad (55)$$

$$\mathbf{A}^T \mathbf{X}_r + \mathbf{X}_r \mathbf{A} + \mathbf{Q} = \mathbf{0} \quad (56)$$

In the general case, where \mathbf{Q} can be selected as any positive semidefinite matrix, there is no explicit relation between Γ_v and \mathbf{W}_c . However, if the matrix \mathbf{Q} is selected as

$$\mathbf{Q} = \gamma \mathbf{B} \mathbf{B}^T \quad (57)$$

as is common in loop-transfer recovery design [16], then by comparing Eq. (17) and (56), it can be shown that \mathbf{X}_r can be expressed in terms of the controllability Grammian as

$$\mathbf{X}_r = \gamma \mathbf{A}^{-T} \mathbf{A} \mathbf{W}_c^\infty \quad (58)$$

and, therefore, the optimal performance is

$$J^* = \gamma \mathbf{x}_0^T \mathbf{A}^{-T} \mathbf{A} \mathbf{W}_c^\infty \mathbf{x}_0. \quad (59)$$

This allows the coupling to be derived as

$$\Gamma_v = \gamma \frac{w_c}{w_a} \begin{bmatrix} \frac{\partial (\mathbf{x}_0^T \mathbf{A}^{-T} \mathbf{A} \mathbf{W}_c^\infty \mathbf{x}_0)}{\partial d_{a_1}} \\ \frac{\partial (\mathbf{x}_0^T \mathbf{A}^{-T} \mathbf{A} \mathbf{W}_c^\infty \mathbf{x}_0)}{\partial d_{a_2}} \\ \vdots \\ \frac{\partial (\mathbf{x}_0^T \mathbf{A}^{-T} \mathbf{A} \mathbf{W}_c^\infty \mathbf{x}_0)}{\partial d_{a_n}} \end{bmatrix}^T \quad (60)$$

which is, again, a function only of the artifact design variables. While this can be a complex expression, depending on the problem in question, it can simplify under certain circumstances. One particular situation is detailed below, in which it takes on a considerably simpler form.

Case IIIa: State \mathbf{x}_0 as a parameter and \mathbf{A} independent of \mathbf{d}_a : If the forced response of a system is a function of \mathbf{d}_a but the free response is not, then the \mathbf{B} matrix will be a function of \mathbf{d}_a but \mathbf{A} will be independent of \mathbf{d}_a . If, in addition, the state \mathbf{x}_0 is a parameter, the coupling relation is given by

$$\Gamma_v = \gamma \frac{w_c}{w_a} \begin{bmatrix} \mathbf{x}_0^T \mathbf{A}^{-T} \mathbf{A} \frac{\partial \mathbf{W}_c^\infty}{\partial d_{a_1}} \mathbf{x}_0 \\ \mathbf{x}_0^T \mathbf{A}^{-T} \mathbf{A} \frac{\partial \mathbf{W}_c^\infty}{\partial d_{a_2}} \mathbf{x}_0 \\ \vdots \\ \mathbf{x}_0^T \mathbf{A}^{-T} \mathbf{A} \frac{\partial \mathbf{W}_c^\infty}{\partial d_{a_n}} \mathbf{x}_0 \end{bmatrix}^T \quad (61)$$

There are several decoupling conditions:

- 1) For all artifact design variables \mathbf{d}_a , the derivative $\frac{\partial \mathbf{W}_c^\infty}{\partial \mathbf{d}_a} = \mathbf{0}$.
- 2) The matrix product $\mathbf{A}^{-T} \mathbf{A} \frac{\partial \mathbf{W}_c^\infty}{\partial \mathbf{d}_a} = \mathbf{0}$ for all artifact design variables \mathbf{d}_a .
- 3) The vectors \mathbf{x}_0 and $\left(\mathbf{A}^{-T} \mathbf{A} \frac{\partial \mathbf{W}_c^\infty}{\partial \mathbf{d}_a} \mathbf{x}_0 \right)$ are orthogonal for all artifact design variables \mathbf{d}_a .

Positioning Gantry Example: Consider, again, the positioning gantry system shown in Section II. In this case, the artifact objective function is assumed to be the system's total weight, which takes the form of

$$f_a(r, k_t) = c_1 + c_2 k_t^{1.5} + c_3 r^2 \quad (62)$$

where $c_1 = 10$, $c_2 = 5$, and $c_3 = 2.5$, subject to the bounds given in Eqs. (32) - (33). The controller optimization problem is formulated as an LQR problem with controller objective $f_c = J$, where J is given by Eq. (50) with $\mathbf{x}_0 = \begin{bmatrix} 3.5 \\ 0 \end{bmatrix}$, $R = 1$, and $\mathbf{Q} = \begin{bmatrix} 0 & 0 \\ 0 & 1 \end{bmatrix}$. The coupling in this case can be shown to vanish for all values of r and k_t , indicating that the problem is uncoupled. When the co-design problem is solved, no tradeoff is seen. For all values of w_a and w_c , $f_a = 81.53$ and $f_c = 5.78$.

V. CONCLUDING REMARKS

In co-design problems where the controller design can be formulated as one of the three classical control problems presented here, there is a strong and fundamental connection between coupling and the controllability Grammian of the system. This relation is independent of the artifact objective function and the controller architecture, and this allows the *a priori* calculation of coupling using the controllability Grammian. The relation between coupling and controllability is limited to linear time-invariant problems which can be formulated as minimum control effort, minimum time, or LQR control problems. These classes of problems, however, are important formulations which are widely applied.

If a problem is known to be decoupled, then it can be solved sequentially with no loss of optimality. Furthermore, when artifact design variables are being chosen, their contribution to coupling can be considered. If a potential design variable participates in coupling, then its effect on the artifact objective function can be evaluated to determine whether it is significant enough to justify the increased problem complexity. It should be noted, however, that while these relations present sufficient conditions for decoupling, they are not necessary. Particular optimal values of the artifact design variables \mathbf{d}_a may result in decoupling.

Future work may include the extension of this work to cover additional types of control problems and special cases within the classes presented here, and application of this work to more complex examples. In addition, these results will facilitate a new solution method for co-design problems

utilizing a Control Proxy Function to represent the system's ease of control.

VI. ACKNOWLEDGMENTS

This work was partially supported by NSF grant #0625060. This support is gratefully acknowledged.

REFERENCES

- [1] R. Haftka, "Integrated structure/control optimization of space structures," *AIAA Journal*, 1990.
- [2] R. Kosut, G. Kabuli, S. Morrison, and Y. Harn, "Simultaneous control and structure design for large space structures," in *Proceedings of the American Control Conference*, San Diego, CA, 1990.
- [3] F. Khorrami and J. Rastegar, "Simultaneous structure and control design for a flexible pointing system actuated by active materials," in *Proceedings of the 34th Conference on Decision & Control*, New Orleans, LA, 1995.
- [4] R. Isermann, "On the design and control of mechatronic systems - a survey," *IEEE Transactions on Industrial Electronics*, vol. 43, pp. 4-15, 1996.
- [5] C. Chen and C. Cheng, "Integrated design for a mechatronic feed drive system of machine tools," in *IEEE/ASME International Conference on Advanced Intelligent Mechatronics*, Monterey, CA, 2005.
- [6] J. Wan, Q. Li, and F. Wu, "Integrated design and control of a closed-chain mechanism," in *Proceedings of the Seventh International Conference on Control, Automation, Robotics and Vision*, Singapore.
- [7] T. Ravichandran, D. Wang, and G. Heppler, "Simultaneous plant-controller design optimization of a two-link planar manipulator," *Mechatronics*, vol. 16, pp. 233-242, 2006.
- [8] H. Wolfram, R. Schmiedel, K. Hiller, T. Aurich, W. Gunther, S. Kurth, J. Mehner, W. Dotzel, and T. Gebner, "Model building, control design and practical implementation of a high precision, high dynamical MEMS acceleration sensor," in *Society of Photo-Optical Instrumentation Engineers*.
- [9] K. Oldham, X. Huang, A. Chahwan, and R. Horowitz, "Design, fabrication and control of a high-aspect ratio microactuator for vibration suppression in a hard disk drive," in *Proceedings of the IFAC World Congress*, Prague, 2005.
- [10] D. L. Peters, K. Kurabayashi, P. Y. Papalambros, and A. G. Ulsoy, "Co-design of a MEMS actuator and its controller using frequency constraints," in *Proceedings of the ASME Dynamic Systems and Control Conferences*. Ann Arbor, MI: ASME, October 2008, paper number DSCC2008-2212.
- [11] H. Fathy, P. Y. Papalambros, and A. G. Ulsoy, "On combined plant and control optimization," in *8th Cairo University International Conference on Mechanical Design and Production*, Cairo, Egypt, January 2004.
- [12] J. A. Reyer, H. Fathy, P. Y. Papalambros, and A. G. Ulsoy, "Comparison of combined embodiment design and control optimization strategies using optimality conditions," in *Proceedings of the ASME Design Engineering Technical Conferences*, J. E. Renaud, Ed., vol. 2. Pittsburgh, PA: ASME, September 2001, pp. 1023-1032, paper number DETC 2001/DAC-21119.
- [13] S. F. Alyaout, P. Y. Papalambros, and A. G. Ulsoy, "Coupling in design and robust control optimization," in *Proceedings of the European Control Conference*, Kos, Greece, July 2007.
- [14] C. Bloebaum, "Coupling strength-based system reduction for complex engineering design," *Structural Optimization*, vol. 10, pp. 113-121, 1995.
- [15] D. L. Peters, P. Y. Papalambros, and A. G. Ulsoy, "On measures of coupling between the artifact and controller optimal design problems," in *Proceedings of the ASME Design Engineering Technical Conference & Computers in Engineering Conference*. San Diego, CA: ASME, 2009, paper number DETC2009-86868.
- [16] S. Skogestad and I. Postlethwaite, *Multivariable Feedback Control: Analysis and Design*. West Sussex, UK: John Wiley and Sons, Ltd., 2005.
- [17] J. A. Bryson and Y. Ho, *Applied Optimal Control*. New York, NY: Hemisphere Publishing Corporation, 1975.
- [18] V. Ionescu, C. Oara, and M. Weiss, *Generalized Riccati Theory and Robust Control*. West Sussex, England: John Wiley & Sons Ltd., 1999.